

# XENIA Series

## REFRIGERATED DISPLAY



MODELS | XENIA 15, XENIA 20, XENIA 25

### XENIA SERIES – REFRIGERATED DISPLAY

Freezing open island XENIA is designed for sale of ice creams, frozen semi-finished products and other frozen products. It is suitable especially for impulse sale of selected kinds of foodstuffs with possibility of personalization according to request of the customer on all four sides of the island. Upper panoramic part made of insulated heated double glass makes excellent visibility of displayed products and solid plastic profile protects the cabinet against damages caused by shopping trolleys. It is plug-in island, fan assisted cooling and automatic electric defrosting are electronically controlled. Xenia is produced in switchable version to be used as freezing or as cooling island.

### FEATURES

- Dual temperature
- Around corner at bottom for easy cleaning
- Ventilated cooling system
- Electronic control system with temperature display
- Temperature sensor
- Automatic defrost
- Large display area
- Massive bumper
- Side insulating glazing
- Deep tub

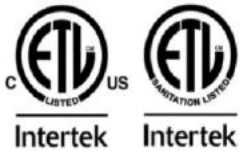

# XENIA Series

## REFRIGERATED DISPLAY

MODELS | XENIA 15, XENIA 20, XENIA 25



### TECHNICAL DATA

MODEL	TEMPERATURE	DIMENSIONS-WxDxH Inches mm	DISPLAY SURFACE m <sup>2</sup>	VOLUME Liters	AMPS	VOLTAGE
XENIA 15	-1°C to 5°C or -18°C to -21°C	60-5/8 x 42-1/8 x 37-1/16 1540 x 960 x 942	1,12	297	15.0	115V
XENIA 20	-1°C to 5°C or -18°C to -21°C	78-3/8 x 42-1/8 x 37-1/16 1990 x 960 x 942	1,49	396	15.0	115V
XENIA 25	-1°C to 5°C or -18°C to -21°C	102 x 42-1/8 x 37-1/16 2590 x 960 x 942	1,99	528	15.0	115V

### CUT VIEW

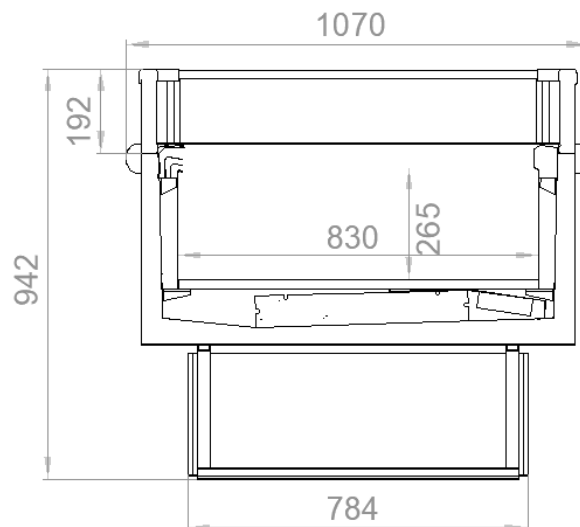

**NOTE :** These merchandisers are designed for use in stores when temperature and humidity do not exceed 24 °C and 55% RN. Designed for holding pre-chilled product only.

We reserve the right to change or revise specifications and product design in connection with any feature of our products. Such changes do not entitle the buyer to corresponding changes, improvements, additions, or replacements for equipment previously sold or shipped.