

MUC Series

UNDERCOUNTER REFRIGERATOR



MODELS | MUC27R, MUC48R, MUC60R, MUC72R

MUC – UNDERCOUNTER REFRIGERATOR

Increase cold food prep storage in your kitchen in a sleek and durable design.

CABINET CONSTRUCTION

Heavy duty construction includes a 304 type stainless steel interior and a 430 type stainless steel exterior, resulting in strength, durability and an attractive, sleek appearance.

Foamed in place CFC and HCFC free polyurethane insulation enhances the structural strength of the cabinet and helps increase energy efficiency.

One-piece rear grill is easily removed for cleaning and servicing.

Door features easy-to-use recessed handles for quick interior access. Doors stays open past 90° for easy loading but will self-close under 90° to save energy.

REFRIGERATION SYSTEM

Environmentally safe R290 refrigerant. Rear-mounted condensing unit positioned for easy maintenance.

MODEL FEATURES

Copper evaporator coil eliminates the potential of corrosion. Interior wall-mounted thermometer for easy temperature monitoring.

Preprogrammed digital controller features auto-defrost function.

SPECIAL FEATURES

- Stainless steel interior and exterior, aluminium back. Option of bright white aluminium interior available
- Refrigeration system keeps food at safe temperatures between 0.5°C to 5°C
- Self-closing doors with 90degree stay-open features
- Shelves : adjustable heavy-duty PVC coated shelves
- Option of backsplashes available
- Electronic control system makes it easy to adjust temperature set point and defrost frequency
- Preinstalled heavy-duty casters with brakes
- Removable installation board makes it easy to access condenser coil for cleaning and service
- Option of different handles available



MUC Series

UNDERCOUNTER REFRIGERATOR



MODELS | MUC27R, MUC48R, MUC60R, MUC72R

TECHNICAL DATA

MODEL	DOORS	WEIGHT N.W (KG) G.W (KG)	TEMPERATURE	REFRIGERANT	DIMENSIONS-WxDxH Inches mm	CAPACITY L FT ³	AMPS	VOLTAGE
MUC27R	1	72 92	0.5°C to 5°C	R290	27 x 29-1/2 x 35-1/5 685 x 750 x 895	177 6.3	1.9	115V 60 Hz
MUC48R	2	210 230	0.5°C to 5°C	R290	47-1/5 x 29-1/2 x 35 1200 x 750 x 895	338 12	2.7	115V 60 Hz
MUC60R	2	250 270	0.5°C to 5°C	R290	60-1/5 x 29-1/2 x 35 1526 x 750 x 895	428 15	2.9	115V 60 Hz
MUC72R	3	285 305	0.5°C to 5°C	R290	72 x 29-1/2 x 35-1/5 1829 x 750 x 895	440 15.5	3.2	115V 60 Hz

PLAN VIEW (MUC48R)

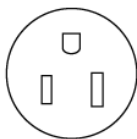
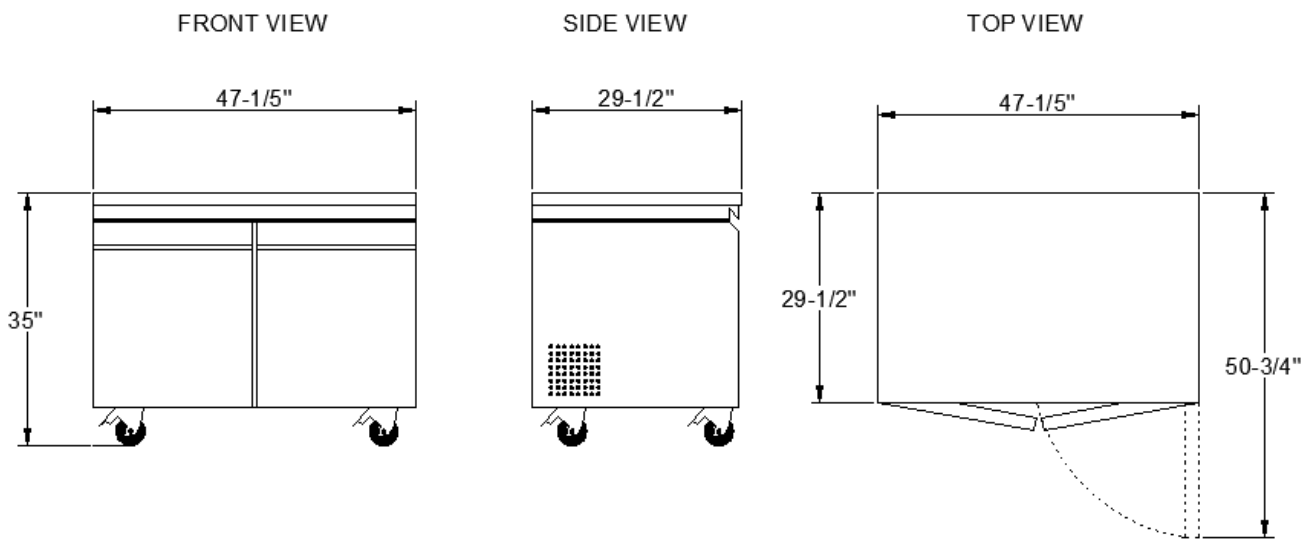

NEMA 5-15P

NOTE: These merchandisers are designed for use in stores when temperature and humidity do not exceed 24 °C and 55% RH. Designed for holding pre-chilled product only.

We reserve the right to change or revise specifications and product design in connection with any feature of our products. Such changes do not entitle the buyer to corresponding changes, improvements, additions, or replacements for equipment previously sold or shipped.