

CONV Series

REFRIGERATED DISPLAY - ISLAND

MODELS | CONV 1250, CONV 1850



XENIA SERIES – REFRIGERATED DISPLAY

The cooling island CONV is created for the sale of packaged foods such as sausages, delicacies or fruits and vegetables, juice, etc. There are in the dead section 2 unrefrigerated shelves and the bottom refrigerated tub. The backlight of the shelves and their staggering ensures perfect visibility of the displayed goods. It is produced in two modules which are usable individually with the sidewall, or built-in to the line.

SPECIAL FEATURES

- Around corner at bottom for easy cleaning
- Ventilated cooling system
- Electronic control system with temperature display
- Temperature sensor
- Automatic defrost
- Large display area
- Bumpers
- Deep tub
- Refrigerated island
- 2 rows of refrigerated shelves
- Head part



CONV Series

REFRIGERATED DISPLAY - ISLAND

MODELS | CONV 1250, CONV 1850



TECHNICAL DATA

MODEL	TEMPERATURE	DIMENSIONS-WxDxH Inches mm	DISPLAY SURFACE m ²	VOLUME Liters	AMPS	VOLTAGE
CONV 1250	2°C to 5°C	50-5/8 x 61-7/16 x 51-1/2 1285 x 1560 x 1308	1,51	493	TBD	TBD
CONV 1850	2°C to 5°C	72-3/4 x 61-7/16 x 51-1/2 1850 x 1560 x 1308	2,17	710	TBD	TBD

CUT VIEW

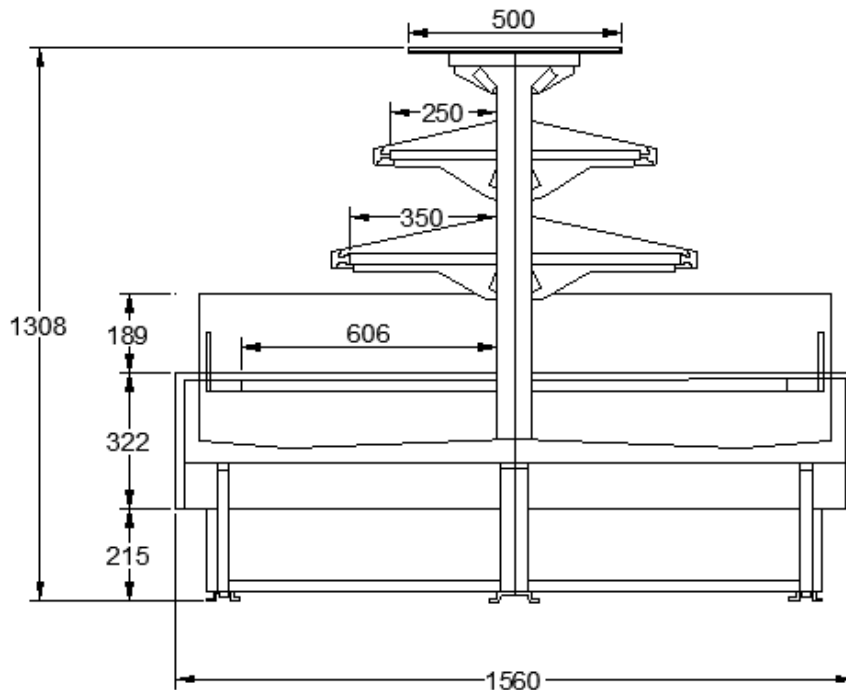

NOTE : These merchandisers are designed for use in stores when temperature and humidity do not exceed 24°C and 55% RN. Designed for holding pre-chilled product only.

We reserve the right to change or revise specifications and product design in connection with any feature of our products. Such changes do not entitle the buyer to corresponding changes, improvements, additions, or replacements for equipment previously sold or shipped.