



- TASTE THE DIFFERENCE -

MODEL B12E

This large-capacity batch freezer produces the highest quality ice cream, gelato, sorbet, Italian ice or sherbets. Mechanically simple and exceptionally dependable, this machine is perfect for gelato, custard and water ice shops.

Model B24E

This high-capacity batch freezer is simple and efficient, making it perfect for gelato, custard and water ice shops.. Make large volumes of your own signature Gelato, Italian Ice, Sorbets and high or low overrun ice cream.

The Electro Freeze Advantage

- **Cam Door latch** provides quick interior access
- **Exclusive Auger Design** gently blends, reducing agitation and maintains product quality and consistency.
- **Auger and Dispensing Head Design** provides excellent product extraction and less flavor overlap.
- **Superior Product Quality** is an Electro Freeze trademark unmatched frozen product quality through simple and effective design
- **Built-in Faucet** with flex hose for fast and easy cleaning
- **Digital timer** with audible alarm
- **Optional Variable Speed Overrun & Viscosity Control** Allows for precise control of viscosity and overrun to maximize your profits. Produces a consistent finished product and automatic shut off when the batch reaches the desired consistency.
- **Extra Large Discharge Chute & Oversized Feed Hopper** allows for quicker dispensing of product for overrun consistency & easier loading of ingredients.
- **Experience Tells** Electro Freeze has been manufacturing quality frozen treat machines since 1929. Superior engineering, product innovations, sturdy construction, quality craftsmanship and dependable performance are Electro Freeze hallmarks.
- **Superior Service Support** backed by a worldwide distributor network.

BATCH FREEZERS

NEW EXTENDED WARRANTY

3 Year Parts*
1 Year Labor
5 Year Compressor



Standard Controls



Shown With Optional Controls

*Excludes normal wear parts, see warranty card for details.

electrofreeze.com

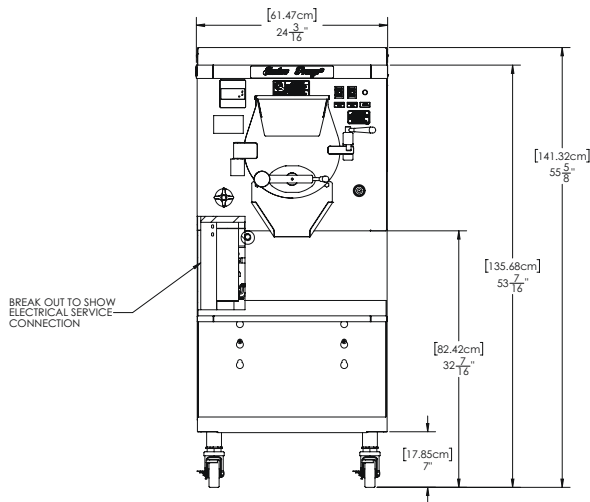

ALL CONNECTIONS ARE MADE THROUGH BOTTOM OF FREEZER

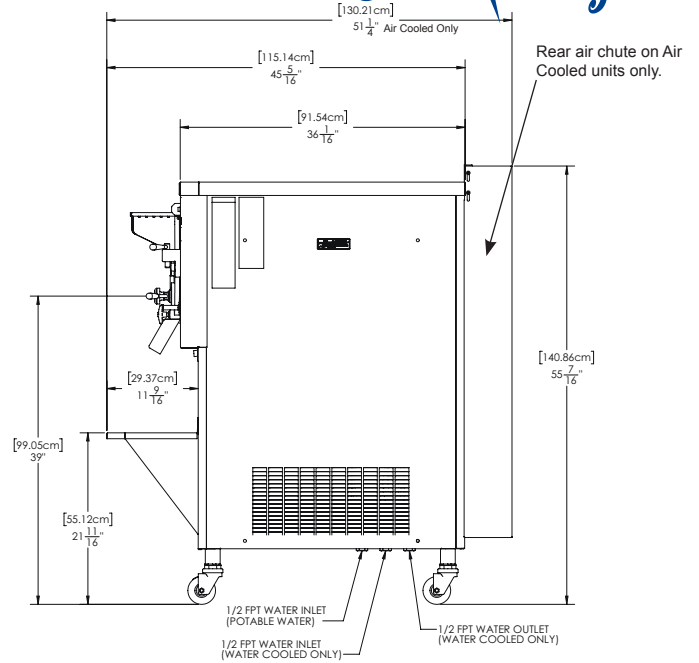

MODEL B12E & B24E SPECIFICATIONS

Due to continual product improvements all specifications are subject to change without notice.

	B12E		B24E		
Weights	lbs.	kgs.	lbs.	kgs.	
Net	605	274	705	320	
Crated	695	315	795	360	
	cu.ft.	cu.m.	cu.ft.	cu.m.	
Volume	58.42	1.65	58.42	1.65	
Dimensions	in.	cm	in.	cm	
Width	24-3/16	61.44	24-3/16	61.44	
Depth-Air	42	106.68	42	106.68	
Depth-Water	36-1/16	61.60	36-1/16	61.60	
Height	53-3/8	135.54	53-3/8	135.54	
Electrical	Maximum Fuse Size*		Minimum Circuit Ampacity*		Poles (P) Wires (W)
	B12E	B24E	B12	B24E	
208-230/60/1 Water	35	65	27.5	46.5	2P, 2W
208-230/60/3 Water	20	40	16.0	28.0	3P, 3W
208-230/60/1 Air	40	70	29.0	48.0	2P, 2W
208-230/60/3 Air	20	40	17.0	29.5	3P, 3W

Electrical characteristics other than above available on request from factory or local distributor. *Check nameplate for exact electrical data.

Bidding Spec

Electrical: Volt _____ Hz _____ Ph _____

Cooling: _____ Neutral _____ Yes _____ No _____

Options: _____



Made in the USA



Electro Freeze div. of H.C. Duke & Son, LLC

2116-8th Avenue, East Moline, Illinois 61244 USA

Phone (309) 755-4553 • (800) 755-4545

FAX (309) 755-9858

E-mail: sales@electrofreeze.com • www.electrofreeze.com

Electrical

A dedicated electrical connection is required for both models. Manufactured to be permanently connected. See electrical chart for the proper requirement. Consult your local electrical codes for cord and receptacle specifications.

Beater Motor

B12E, 2.5hp. (1.9kW)

B24E, 3hp. (2.23kW)

Refrigeration Systems

B12E, 2.5hp. (1.9kW) R404a.

B24E, 3.5hp. (2.61kW) R404a.

Air/Water Cooled

3" (7.6 cm) is required on both side panels for proper air circulation.

Water Cooled

Water pressure between 35-140 psig (241-965 kPa) for proper operation.

Freezing Cylinder Capacity:

B12E, 14 quarts (13.25 liters)

B24E, 26 quarts (24.6 liters)

Certified and/or listed by:



*UL listed and listed by Underwriters Laboratories under Canadian National Standard C22.2 No. 120-13

Authorized Distributor